



# IRB-MON2™

Universal UL325 Thru Beam Photoeye



## Instruction Manual

The IRB-MON2 thru beam infrared photoeye is an external entrapment protection device type B1, non-contact sensor for use with automatic gates and doors. The photoeye provides a signal to the gate or door operator that the beam is, or is not obstructed. It operates up to 115 feet over a wide range of input voltages (6-35 VDC and 12-24 VAC). The receiver green alignment indicator provides status information, making set-up and alignment easy. The IRB-MON2 provides compatibility with most operators that accommodate monitored external entrapment devices per UL325.

### Cautions and Warnings



This product is an accessory or part of a system. Install the IRB-MON2 according to instructions from the gate or door operator manufacturer. Comply with all applicable codes and safety regulations.

### Specifications

Operating Range	5 to 115 ft (35 m)
Power	6-35 VDC, 12-24 VAC
Current (NC and 10K Monitoring Methods)	35 mA DC (when aligned and relay activated)
Current (Pulse Monitoring Methods)	15 mA
Connections	“Removable” screw terminal for easy wiring
Supported Monitoring Methods	10K, 2-wire pulse, Normally Closed (power cycle)
Relay Output Configuration	Form C contacts (NO, COM, NC)
Response Time	<300 mS (for use in NC or 10K monitoring)
Operating Temperature	-40° to 170°F (-40° to 77°C)
Dimensions (L x W x H)	3.6” (91 mm) x 2.9” (74 mm) x 2.9” (74 mm)
Conduit Hole Size (bottom of the housing)	½ Inch NPT

### Ordering Information

- IRB-MON2-HD – Gray powder-coated metal protective hoods

## Monitoring Methods

UL325 requires continuous monitoring of all safety devices connected to gate and door operators. Consult the gate or door operator manufacturer's instruction manual for necessary monitoring method.

- **Normally Closed** (Wiring Diagram A): The operator cycles power to the transmitter while monitoring the receiver N.C. (Normally closed) contacts for proper operation
- **10K Resistive Termination** (Wiring Diagram B): Provides a measurable 10K ohm resistance across the N.O. (normally open) relay when unobstructed and in Fail Safe mode
- **Two-Wire Pulse, 2 Frequency** (Wiring Diagram C): Provides 300Hz "heartbeat" unobstructed, 0Hz obstructed over the receiver input power supply lines
- **Two-Wire Pulse, 3 Frequency** (Wiring Diagram D): Provides 300Hz "heartbeat" unobstructed, 2Hz obstructed, and 0Hz when failure is detected, over the receiver input power supply lines

## Board Diagram

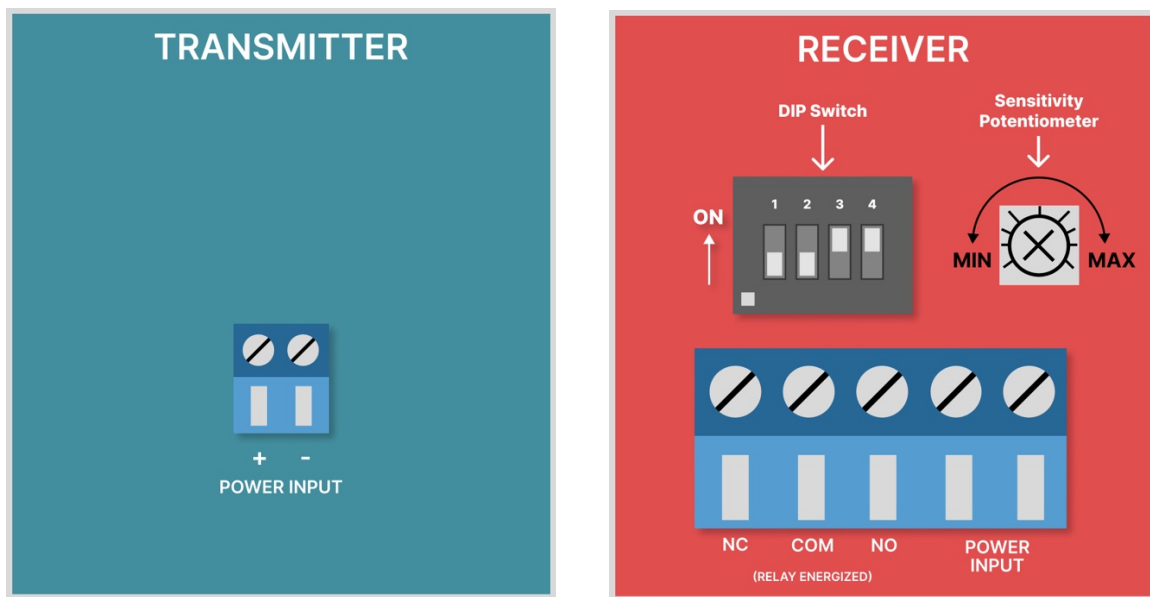

### Sensitivity Potentiometer

Clockwise is maximum sensitivity

Counter-clockwise is minimum sensitivity

# Installation

- Determine the IRB-MON2 mounting location (4-25 inches above the ground).
- Deactivate the gate or door during photoeye installation.
- **The IRB-MON2 cannot be used for a detection range of less than 5 feet.**

**1. SET DIPSWITCH FOR MONITORING METHOD:** Check the GATE or DOOR OPERATOR manual (or call the operator company) to determine which monitoring method is necessary for your operator. Remove the front covers (remove 4 plastic screws in each unit), and then set IRB-MON2 dipswitches per pages 4 & 5 for the needed operator monitoring method.

**2. MOUNTING:** Determine your mounting height from 4 to 25 inches above the ground, and mount the housings using 4 screws (not supplied) that go through the inside of the housing, inside of the 4 holes in the corners (same holes where the plastic screws came out of).

**3. WIRING:** Connect 6-35 VDC or 12-24 VAC to the "Power Input" terminals on the transmitter (marked "+ -") and receiver (marked "PWR"). Remove (pull up on) the green screw terminals for ease of wiring. Wire according to the page 5 diagram that corresponds to your operator monitoring method. Wiring must enter via UL listed watertight conduit fitting such as a 1/2" watertight conduit connector, through the bottom of the housing.

**NOTE: MUST USE 6-35 VDC FOR PULSE MONITORING.**

**4. OPTIONAL:** Install optional sunshield over the receiver reflector to reduce the effects of sun interference or cross talk.

**5. POWER:** Apply power to the IRB-MON2 transmitter and receiver.

**6. ALIGNED CORRECTLY:** The receiver and transmitter are aligned when the RECEIVER green LED is on "solid". Once on solid, then slowly decrease the sensitivity setting on the receiver (turn potentiometer counter clockwise) until the receiver green LED just starts to flash. Now, increase sensitivity setting "one quarter" turn clockwise. Confirm receiver LED is still on solid.

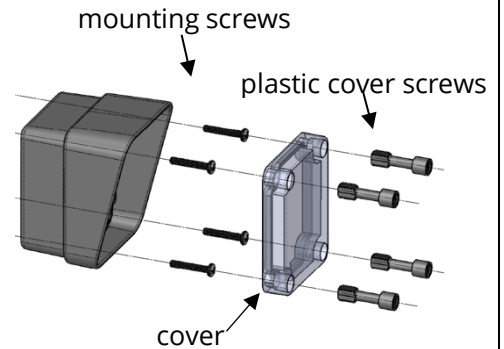
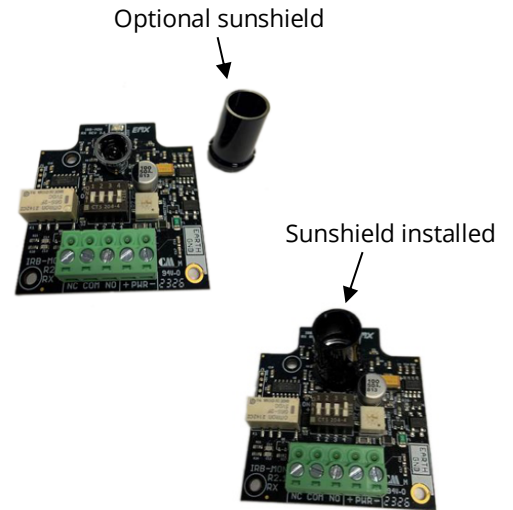

### LED Indicators

Transmitter - Green LED on	Power
Receiver - Green LED on solid	Aligned
Receiver - Green LED flashing	Beam blocked or not aligned

**8. TEST OBSTRUCTION:** Place an obstruction (ex. hand) between the transmitter and receiver -- The receiver green LED should start flashing. Check the operator control board and verify the safety input is recognized by the operator. Test the beam with an obstruction between transmitter and receiver at multiple distances to confirm proper operation.

**9. REMOVE OBSTRUCTION:** Remove the obstruction and the receiver green LED will turn on solid.

**TIP:** If the IRB-MON2 is aligned but not detecting an obstruction, slowly reduce the receiver sensitivity (counter-clockwise) until the obstruction is detected. This may be applicable for installations with a detection zone of less than 20 ft.

**10. SECURE THE COVERS:** Secure the covers using all four plastic screws provided (do not over tighten the screws but make them snug). **Done!**

## Configuration Settings

Monitoring Method	Wiring Diagram	DIP Switch Settings				Output Connections	10K State
		SW1	SW2	SW3	SW4		
Normally Closed	A	OFF	OFF	ON	OFF	NC, COM	10K DISABLED
10K Resistive Termination	B	OFF	OFF	ON	ON	NO, COM	10K ENABLED
Two-Wire Pulse (2 Frequency: 300Hz, 0Hz)	C	ON	OFF	OFF	OFF	DC POWER	N/A
Two-Wire Pulse (3 Frequency: 300Hz, 2Hz, 0Hz)	D	OFF	ON	OFF	OFF	DC POWER	N/A

- **FAIL SAFE** (Wiring Diagram A or B) - **Most common monitoring method - Gate opens with loss of power** - DIP switches shown as in the table above for monitored “Normally Closed” or “10K Resistive Termination”. The relay will change state during a loss of power (N.C. will open, and N.O. will close). **NOTE: Use this mode in all normal operations and UL325 monitoring scenarios.**
- **FAIL SECURE** (Wiring Diagram A or B) - **Less common monitoring method, Gate closes/secures with loss of power** - To achieve Fail Secure for either “Normally Closed” or “10K resistive termination”, configure dipswitches the same as shown in the above table “EXCEPT” SW1 needs to be ON. The relay will function opposite what is written on the PCB. When powered on and aligned the N.O. relay will be closed, and the N.C. contact will be open. The relay WILL NOT change states during loss of power so the gate stays closed during power loss (N.O. will close, and N.C. will open).
- **Two-Wire Pulse Monitoring** (Wiring Diagram C or D) - **Must use 6-35 VDC (can't use AC power in two-wire pulse mode)** and requires a compatible operator board with the current limiting circuitry.

**Note: If using the IRB-MON in an application that requires Normally Open, but does not require a 10K resistor across the normally open contact then wire according to diagram B with dipswitch SW4 set to OFF.**

# Wiring Diagrams

**Wire Diagram A: Normally Closed**

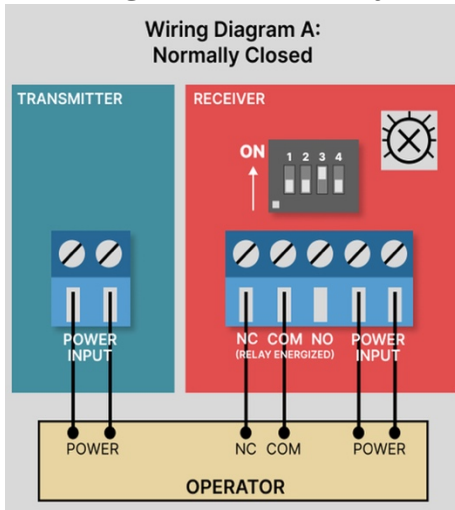

**Wiring Diagram B:  
10K Resistive Termination**

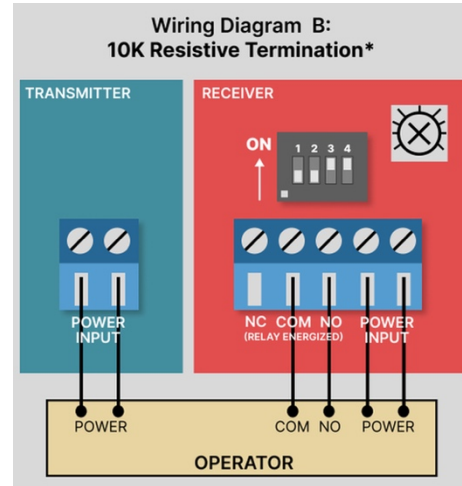

**\*If you need a normally open relay, but without a 10K resistor then set Dipswitch 4 to OFF. This is a non-monitored method.**

**Wiring Diagram C:  
Two-Wire Pulse (2 Frequency)**

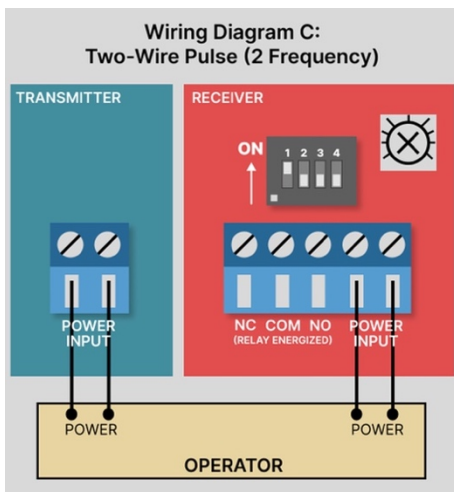

**Wiring Diagram D:  
Two-Wire Pulse (3 Frequency)**

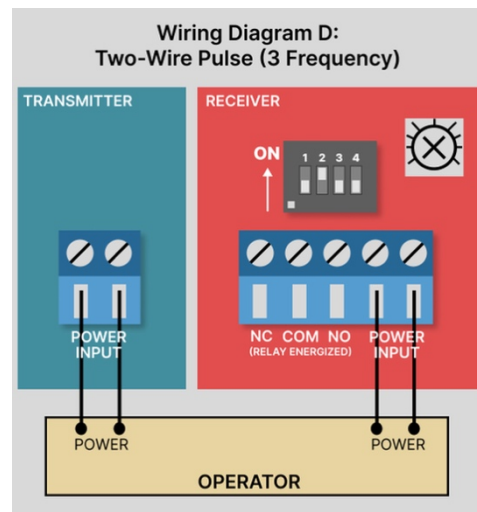

## Troubleshooting

Symptom	Possible Cause	Solution
Does not detect obstruction	Sensitivity is too high  Signal is reflecting off another surface	Decrease sensitivity potentiometer counter-clockwise  Check area for highly reflective surfaces
Receiver green LED flashes continuously, indicating an obstruction when one is not present	Sensitivity is too low  Transmitter does not have power  Receiver does not "see" transmitter	Increase sensitivity potentiometer clockwise  Check power source of transmitter  Make sure transmitter and receiver are aligned
Receiver activates but does not transmit signal to operator	Faulty connection between receiver and operator control input	Verify all wires and terminal connections
Receiver green LED off	Transmitter too close to receiver	Decrease sensitivity (potentiometer counter-clockwise)  Increase distance between transmitter and receiver
Output relay chatters constantly between open and close	All 4 DIP switches are in the OFF position	Operator expects Diagram C or D but dipswitches are configured according to Diagram A or B on page 4

## Warranty

EMX Industries, Inc. products have a warranty against defects in materials and workmanship for a period of two years from the date of sale to our customer.