

DRIVEGUARD ULTRA INSTALLATION/OPERATION MANUAL

Features of the *DRIVEGUARD ULTRA™* Driveway System:

- ◆ Advanced lightning protection
- ◆ Sensor probe supervision
- ◆ Accommodates 100 sensor probes
- ◆ Transient suppressor reduces false alarms
- ◆ Improved RFI immunity
- ◆ Adjustable exit delay (50 seconds to 15 minutes)
- ◆ Adjustable re-trigger hold-off (1 second to 2½ minutes)
- ◆ Adjustable annunciator time with extra annunciator form "C" relay contacts (½ second to 30 seconds)
- ◆ Adjustable floodlight relay entry delay time (1 second to 2½ minutes)
- ◆ Adjustable floodlight relay time (15 seconds to 15 minutes)
- ◆ Built-in battery charger allows annunciation during power outage (battery not included)
- ◆ Manual trip-test button
- ◆ Floodlight N.O. relay contact rating is 15 amps at 125 VAC
- ◆ Floodlight relay can be used to switch on up to 1800 watts of lights
- ◆ Floodlight relay can be used to operate coil of multi-contact relay or contactor and thus operate many banks of lights
- ◆ Floodlight relay can be used to switch low voltage devices such as line carrier interface modules
- ◆ Photocell daytime lockout keeps lights from coming on during daylight hours
- ◆ Adjustable photocell sensitivity
- ◆ Automatic increase of floodlight relay time when additional vehicles are detected
- ◆ "Instant-On" feature when floodlight timer is activated by the manual button on the CT-A1 annunciator plate
- ◆ Floodlight timer instant reset on the CT-A1 annunciator plate

CONSUMER INFORMATION:

DATE PURCHASED: _____

DATE INSTALLED: _____

SERIAL NUMBER: _____

(Located on black relay on circuit board)

TABLE OF CONTENTS

Introduction1
 Serial Number1
 Location of Control Unit1
 Floodlight Relay Wires1
 Installing Control Unit.....1
 Power and Battery Backup.....2
 Earth Ground3
 Trip-Test Button3
 Extra Set of Relay Contacts3
 Integrating With a Security or Home Automation Panel3
 CT-6 Probe and Wire Check-out.....3
 System and Probe Don'ts4
 Location of CT-6 Probe4
 Installing CT-6 Probe and Cable5
 Connecting CT-6 Probe to Control Unit6
 Multi-Probe Assemblies6
 Phasing Probes.....6
 Probe System Supervision.....6
 Using Probe Fault Mode for Testing6
 SD-6 Short Driveway Probe System7
 Connecting Other Sensing Devices to Control Unit7
 Installing Photocell Block7
 Installing Sounders (Annunciators)7
 Adjusting CT-A1 Exit Delay.....9
 Adjusting Sounder (Annunciator) Time10
 Adjusting Re-Trigger Hold-Off.....10
 Adjusting Floodlight Entry Delay Time10
 Adjusting Floodlight Time.....11
 Adjusting Photocell Sensitivity11
 Adjusting Probe Sensitivity.....11
 Adjusting Transient Suppressor11
 Field Troubleshooting11
 Splicing Probe Cable12
 Warranty Information13
 Merchandise Return Information.....13
 Technical Specifications13

TECHNICAL SPECIFICATIONS - CF-2C CONTROL UNIT

POWER REQUIRED:	12 VAC or 12-15 VDC
STANDBY CURRENT:	35 mA
ALARM CURRENT:	180 mA max. with (1) FC-9 or (1) CT-8
RELAY CONTACT RATING:	Double Pole, Double Throw 1st Pole: 12 VDC, 200 mA for remotes 2nd Pole: SPDT, 5 amps, 30 VDC
RELAY TIME:	1/2 to 30 seconds
FLOODLIGHT CONTACT	SPST, 15 amp, 125 VAC CSA certified (1800 watts)
FLOODLIGHT TIME	15 seconds to 15 minutes
FLOODLIGHT DELAY	1 second to 2 1/2 minutes
BATTERY CHARGER	13.5 VDC, 5 mA minimum charge (w/ voltage off)
TEMPERATURE RANGE:	35° F. to 140° F.
DIMENSIONS:	7 1/2 in. x 12 3/4 in. x 3 in.
WEIGHT:	5 lbs.

TECHNICAL SPECIFICATIONS - CT-6 PROBE

TEMPERATURE RANGE:	-40° F - +250° F
PROBE DIMENSIONS:	16 1/2 in. x 1 3/8 in. diameter
WEIGHT:	3.5 lbs. with 100' cable
OTHER:	500 to 800 ohms coil resistance depending on length of cable

- ◆ Testing photocell, page 7
- ◆ Location of CT-A1, page 8
- ◆ Entry delay time, page 10

When trouble-shooting a CF-2C system that is false alarming, check the ground system. House electrical panel grounds can cause transient feedback that could cause false alarms.

To determine if false alarms are board related or probe system related, disconnect the probe and connect a 500 to 1000 ohm resistor across terminals 17 and 19 and leave it connected for a long period of time. If the board false alarms, it is circuit board related or ground system related. If it does not false alarm with the resistor installed, then the probe system is suspect.

NOTE: when troubleshooting the CF-2C, an active cell phone within five feet of the control unit will cause the system to false alarm.

If either the probe or control unit fails the test, call Cartell's technical staff using the 717-532-0033 number. Further instructions will be given or authorization to return the ostensibly defective product for testing and repair. If the probe is bad, there is no way of repairing it. It is recommended that all repairs be returned directly to Cartell and not be sent through a distributor.

SPlicing PROBE CABLE

The cable supplied with your system is coated with polyurethane because it will bond with epoxy and make a sealed splice. If you purchase your own cable, make sure it is polyurethane coated or it will not splice. Improper cable splices will cause false alarms. To insure a proper splice, follow the instructions below.

Two items are necessary when splicing, both available from Cartell: First, a two-wire shielded direct burial cable (unshielded cable and PVC jacketed cable will not give proper splices). Second, an underground splice kit (made by 3M, part #82-F1; Cartell's part number is CA-1). The following instructions assume you have these products.

1. See Figure A. Strip the outer jacket on one cable back 10 inches and cut the RED and BLACK leads to 3 inches. Leave the SHIELD drain wire the full 10 inch length. Strip the outer jacket off the mating cable back 3 inches and strip the jacket of the RED and BLACK lead of both cables back ½ inch. Twist the BLACK to BLACK and RED to RED and solder the connections.
2. See Figure B. Trim the RED and BLACK joints and tape for proper insulation. Twist the 3 inch SHIELD drain wire to the 10 inch SHIELD drain wire and solder the connection. DO NOT cut off the excess SHIELD drain wire.
3. See Figure C. Wrap aluminum foil around the splice area (to properly shield it). Wrap the 10 inch SHIELD drain wire tightly around the outside of the foil and solder it to itself in order to hold it in place. This procedure insures that any signal to the splice SHIELD will drain to ground and thus prevent false alarms.
4. See Figure D. Place an underground splice kit potting container around the spliced cable and epoxy, following the kit instructions carefully.

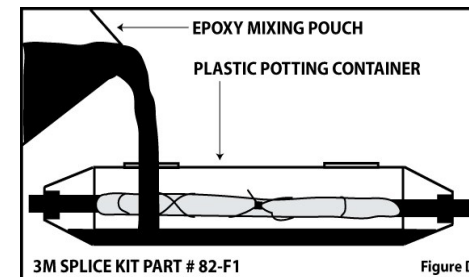
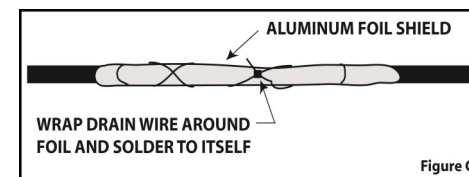
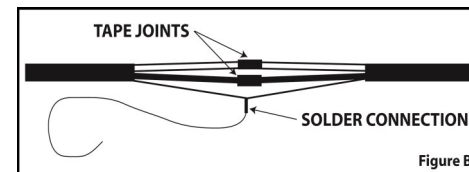
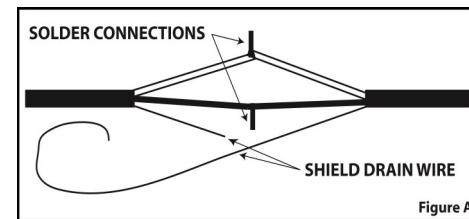

INTRODUCTION

Thank you and congratulations on purchasing the most professional vehicle detection system available! It has been manufactured to give years of trouble-free service. However, if it should need servicing, please consult the dealer/installer who installed your system.

Read these instructions completely. Each system should be bench-tested by the dealer/installer before installation. The installer should become acquainted with the CF-2C control unit and sensor probe in the shop; make all adjustments and settings; and study all system functions. If there are any questions or problems that need to be discussed, contact the technical staff by calling our 800 number.

SPECIAL NOTE: Look for information gleaned from the field contained under the heading "SPECIAL NOTE" throughout this manual (see "Field Troubleshooting" on page 11 for a complete list of them).

SERIAL NUMBER:

Attached to the relay on the circuit board is a sticker with a set of numbers and letters. This series of numbers and letters reveals the specific unit, its year of manufacture, its issue number, and ends with the serial number (see illustration).

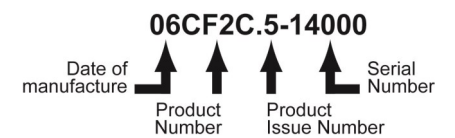

When calling Cartell for technical help, please have these numbers handy so your call may be handled in a timely manner.

LOCATION OF CONTROL UNIT

Install the control unit in a dry, weatherproof building away from heavy electrical motors, radio transmitters, main power service, or any equipment that may introduce electrical or R. F. noise. Install control unit in a sealed box when used in a corrosive atmosphere such as an animal barn or chemical plant.

Install in a sealed, weather-proof box when installed outside. The weatherproof box must have a thermostatically controlled light bulb or heater to maintain temperatures above freezing. Drastic changes in temperature cause condensation on the board and will make the unit malfunction.

FLOODLIGHT RELAY WIRES

On the CF-2C circuit board is a floodlight relay (normally open, dry contact) rated 15 amps at 115 VAC. Two 12 gauge, black wires connected to this relay exit out the back of the CF-2C case. This floodlight relay can be used to operate three types of systems:

1. The relay can be used to operate up to 1800 watts directly (see Figures 1A, 1B, and 1C and "Installing Control Unit" next page).
2. The relay can be used to operate the coil of an auxiliary relay or contactor to power banks of lights (see "Installing Control Unit" below).
3. The relay can be used to activate low voltage lighting up to 15 amps maximum.

INSTALLING CONTROL UNIT

See Figure 1, top of next page. Install a single-gang electrical box in the wall behind the control unit so that the black wires from the unit go directly into the electrical box.

With the power to the floodlight switching system off, run a 14-gauge, two-wire Romex cable from the new single-gang electrical box to the existing floodlight switching system as shown in Figure 1A. Connect the Romex cable across the switch of a single-switch system as shown in Figure 1B.

Figure 1

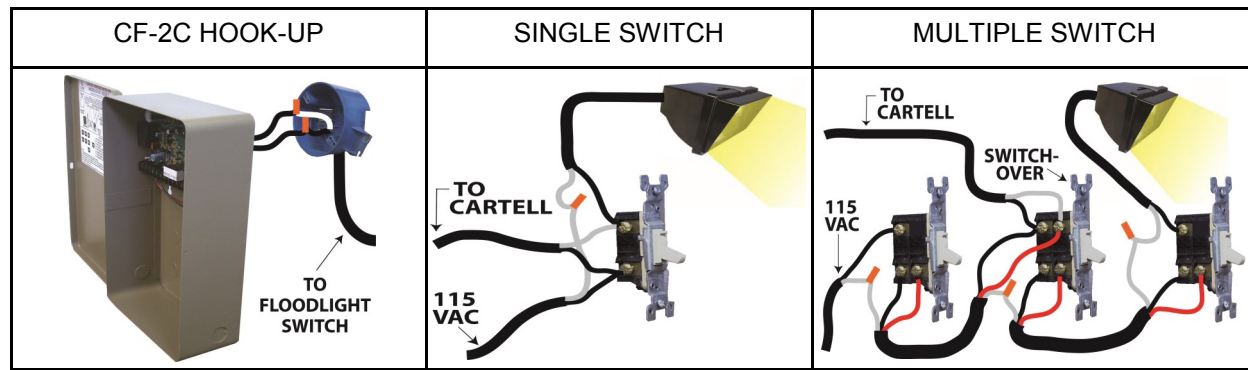

Figure 1A

Figure 1B

Figure 1C

Connect the Romex cable across the "A" and "B" screw terminals of any switch in a multiple-switch system as shown in Figure 1C.

Connect the black leads from the control unit to the two wires of the Romex cable with wire nuts as shown in Figure 1A.

Mount the control unit to the wall over the electrical box as shown.

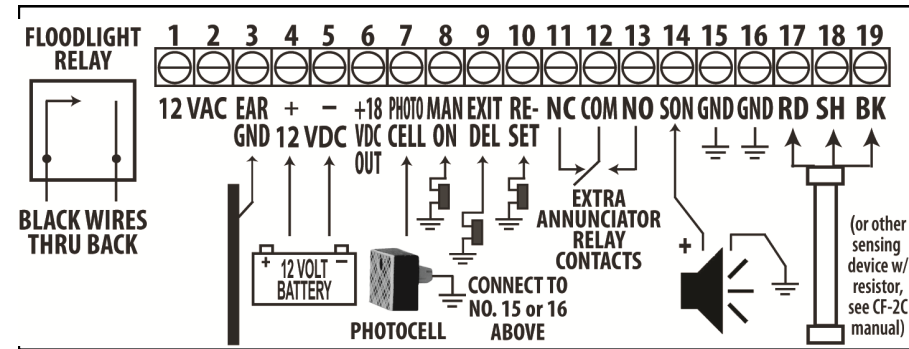

Figure 2

POWER AND BATTERY BACKUP

See Figure 2. The control unit operates on 12 VAC or 12 VDC. Connect the 12 VAC transformer between terminals No. 1 and 2 as shown in Figure 2 (NOTE: DO NOT connect a DC power source to terminals 1 and 2).

A built-in battery charger will keep a 12 volt sealed lead-acid battery (not included) charged for operating the sounder Sonalert during power failure. **NOTE: The battery back-up is not needed for normal operation of the CF-2C control.** If you choose to purchase a battery, only a sealed lead acid (starved, wet-cell) battery should be used. DO NOT use a gelled-electrolyte battery. Recommended batteries are made by Yuasa Battery, Inc.; Gates Energy Products, Inc.; Eagle Picher Industries, Inc.; Panasonic Industries, Co.; or G.S. Battery, Inc.

The positive (RED) lead connected to terminal No. 4 and the negative (BLACK) lead connected to terminal No. 5 are provided for connections to the battery. When an outside DC power source is being used, connect to these terminals in place of a battery.

SPECIAL NOTE: During initial power-up or power-down and power-up sequence, the "Exit Delay" timer is automatically activated. Be patient, for the CF-2C control cannot be accessed until the "Exit Delay" timer times out. It is recommended that when the control unit is first installed that the "Exit Delay" adjustment (potentiometer "C") be set at minimum (fully counter-clockwise) until the system is operational. (See "Adjusting CT-A1 Exit Delay" on page 9.)

ADJUSTING FLOODLIGHT TIME

See Figure 6 on page 10. The amount of time the floodlights remain on after the system is tripped may be adjusted from 15 seconds to 15 minutes. The normal floodlight time is 5-10 minutes.

To set the floodlight time, remove the photocell wire from terminal No. 7. Push the TRIP-TEST button. Measure from the moment the floodlight relay clicks on to the moment it clicks off. Adjust potentiometer "B" (clockwise for time increase) and repeat until desired time is achieved. Reconnect the photocell wire to terminal No. 7.

ADJUSTING PHOTOCELL SENSITIVITY

See Figure 6 on page 10. Photocell sensitivity determines the level of outdoor light at which the lights are allowed to come on. The factory sets the floodlights to come on at dusk.

To set the photocell sensitivity, make all adjustments at the precise moment when the amount of daylight is visible at which time you want the floodlights to come on. Adjust potentiometer "D" counter clockwise in very small increments and push the TRIP-TEST button after each adjustment (see page 3). Stop adjusting at the point where the floodlight relay clicks on. The floodlights will be allowed to turn on at that same daylight level from then on.

ADJUSTING PROBE SENSITIVITY

See Figure 6 on page 10. Probe sensitivity is set at the factory and does not usually need to be adjusted. Factory setting allows a single standard probe to cover a 12 foot wide driveway when installed beside it (see "Installing CT-6 Probe and Cable" on page 5). Increasing the sensitivity above the factory setting is not recommended unless the probe is located in a low sensitivity area.

When the probe is placed in the center of a driveway that is 18 feet wide or less, the sensitivity may be decreased considerably, allowing the probe to be installed close to highway traffic or power lines.

To adjust probe sensitivity, turn the potentiometer "G" clockwise to increase, counter-clockwise to decrease. A typical setting should be such that the CF-2C reliably detects a small car going 5 MPH. You may increase sensitivity if necessary. Be aware, increasing sensitivity may cause false alarms.

ADJUSTING TRANSIENT SUPPRESSOR

See Figure 6 on page 10. The factory setting for the transient suppressor circuit potentiometer "H" is in the "on" position (fully clockwise). In this setting, short duration transient signals will be ignored. With the circuit activated, false alarms from lightning will be reduced.

Note: if the probe sensitivity cannot be properly set as described in the "Adjusting Probe Sensitivity" section (above), turn off the transient suppressor by adjusting potentiometer "H" fully counter-clockwise.

FIELD TROUBLESHOOTING

Cartell does not provide schematic diagrams or service manuals for our products. However, we try our best to provide technical support through our 717-532-0033 number and fast repair service for our products. Before calling Cartell, refer to the "SPECIAL NOTE" sections under the following headings:

- ◆ Initial power-up and exit delay, page 2
- ◆ Purchasing ground rod, page 3
- ◆ Sensor probe check of existing installations, page 4
- ◆ Probe system supervision, page 6
- ◆ Using Probe Fault Mode to test circuit board, page 6

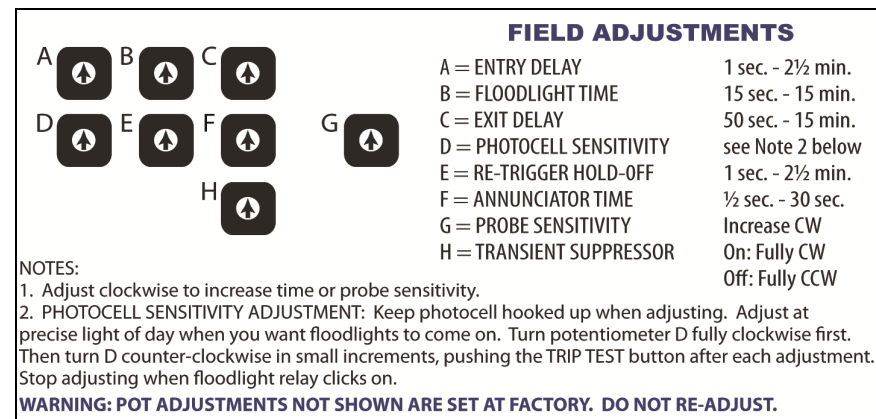

Figure 6

ADJUSTING SOUNDER (ANNUNCIATOR) TIME

See Figure 6. This function controls the amount of time the customer desires the noisemaker to stay on. It may be adjusted to stay on anywhere from 1/2 to 30 seconds. To adjust, use the potentiometer marked "F". Turning it clockwise increases the time. Push the trip-test switch to hear your adjustment. Adjust until the desired time is achieved.

NOTE: Each CT-A1 may be adjusted individually from its own circuit board (see "Adjust Timing" instructions under CT-A1 operational features, page 8).

ADJUSTING RE-TRIGGER HOLD-OFF

See Figure 6. The re-trigger hold-off keeps the system from re-triggering (and thus annunciating) should multiple cars pass the probe in a caravan. Once the system is tripped, it will time-out but not be able to re-trigger for an adjustable time period up to 2½ minutes. To adjust this time period, disconnect the RED probe wire from terminal No. 17 (this puts the control unit in PROBE FAULT mode, see page 6).

The annunciator relay will constantly cycle on and off. To increase the re-trigger hold-off, adjust potentiometer marked "E". Turn it clockwise for a longer hold-off period of time. Repeat until the desired hold-off time is achieved. Re-attach the RED probe wire.

ADJUSTING FLOODLIGHT ENTRY DELAY TIME

See Figure 6. This function can be used to delay activation of the floodlight timer after the CF-2C is tripped. Adjustment time is from 1 second up to 2½ minutes. For long driveways, or if the exact location of the probe is to be concealed for security reasons, use this feature. The annunciator, however, is not delayed.

To set the desired floodlight entry delay timer, first remove the photocell lead from terminal No. 7 (see Figure 2 on page 2) on the CF-2C control unit. Push the TRIP TEST button and measure from the moment the annunciator relay clicks on (a relatively quick click) and the moment the floodlight relay activates (a relatively loud click).

To increase the delay time, adjust the potentiometer marked "A" clockwise. After the floodlight relay times out, repeat the cycle until the desired time is achieved. Re-connect the photocell wire to terminal No. 7.

SPECIAL NOTE: Do not use the "ON" button on the CT-A1 annunciator plate to set the entry delay time. On the CF-2C, the "ON" button on the CT-A1 instantly activates the floodlight timer, bypassing the entry delay timer circuit.

EARTH-GROUND

See Figure 2 on page 2. A proper earth-ground is essential. A proper earth-ground is established by using an 8 foot copper or copper-clad ground rod driven deeply into the earth.

Use a ground wire of at least 12 gauge. Solder wire to ground rod and then clamp it. Tin the other end of the ground wire and connect it to terminal No. 3 on the control unit.

SPECIAL NOTE: A galvanized ground rod will not give this system a proper ground. Use copper-clad.

TRIP-TEST BUTTON

The trip-test button, located center right on the circuit board, is a tool to evaluate most of the control electronics and to help in setting the relay time. To test the control unit, a working probe must be attached to terminals No. 17, 18, and 19 (see Figure 2 on page 2). If the probe is disabled or not connected, simply connect a 500 - 1000 ohm resistor between the probe terminals No. 17 and 19. NOTE: The TRIP TEST button will not work if the PROBE FAULT LED is lit (this indicates a disabled probe).

Set the probe sensitivity potentiometer "G" to the halfway point, i.e., vertically up and down (see Figure 6 on page 10). Push the TRIP-TEST button on and off quickly. DO NOT hold the button on. The signal generated simulates that of a detected vehicle. No response indicates component failure on the circuit board or failure of the power supply. It may be that the EXIT DELAY timer has not timed out as well (the EXIT DELAY time may have been preset anywhere between 50 seconds and 15 minutes (see "Adjusting CT-A1 Exit Delay" on page 9).

EXTRA SET OF RELAY CONTACTS

The annunciator relay has a second set of Form "C" relay contacts on terminals No. 11, 12, and 13. These contacts may be used to trip an alarm panel, trip a dialer, trip a line carrier interface, trigger a transmitter or trip a door bell. Potentiometer "F" controls the relay time of these contacts.

INTEGRATING WITH A SECURITY OR HOME AUTOMATION PANEL

See Figure 2 on page 2. The CF-2C has a floating, dry relay contact that can be used in conjunction with any security or home automation (H. A.) system.

Two things will help you have a successful installation:

1. The manual for your home automation or security panel
2. A resistor, if required (security or H.A. system manual will tell you if a resistor is required)

Note: Use the power supply that came with the CF-2C to power it rather than relying on the H.A. or security panel for power.

Hook the CF-2C to two zone inputs on your security or H.A. panel. If your system's contacts are normally closed, use terminals 11 & 12 on the CF-2C. At your system's panel, place a resistor (if required) between the terminals in parallel (see system manual for correct resistor size).

If your security or H.A. contacts are normally open, use terminals 12 & 13 on the CF-2C and place a resistor (if required) between the terminals in series (see system manual for correct resistor size).

CT-6 PROBE AND WIRE CHECK-OUT

It is advisable to check the CT-6 probe assembly before and after installation in the earth. Use a good multimeter. With the probe wire disconnected from the control unit, measure the resistance between the RED and BLACK leads. It should read between 500 and 800 ohms for a single probe. Additional probes on the system will add approximately 620 ohms each. The reading should be stable with zero fluctuations.

The resistance between the RED lead and the SHIELD (bare wire), or the BLACK lead and the SHIELD should be millions of ohms. The resistance between the SHIELD drain wire and earth-ground should be millions of ohms.

While making measurements to the shield drain wire, do not touch the bare wire or the multimeter leads with your fingers as that will spoil the readings.

SPECIAL NOTE: *On an existing installation, if a bad probe is indicated, it may be wire damage, lightning damage to the probe, or an improper splice.*

An open between all three wires usually indicates lightning damage to the probe. Dig up the probe and cut the cable several feet from the probe and test the probe. A damaged probe can be replaced by splicing a probe with a short lead on to the existing wire (see "Splicing Probe Cable" on page 12.)

Leakage between the three wires may indicate wire damage. Leakage from RED or BLACK wires to the SHIELD (bare) wire may indicate wire damage. Erratic resistance readings may indicate an improper wire splice.

SYSTEM AND PROBE DON'TS

- DO NOT use double sided tape to mount the circuit board on another surface, if you should decide to take the circuit board out of its case (not advisable).
- DO NOT bury the probe within 6 to 10 feet of a buried power or telephone line.
- DO NOT bury the probe within 6 to 10 feet of a buried invisible dog fence.
- DO NOT bury the probe within 10 feet of a natural gas line.
- DO NOT bury the probe within 20 feet of a power pole with a transformer attached to it.
- DO NOT bury the probe within 100 feet of railroad traffic.
- DO NOT bury the probe within 200 feet of sub-station type overhead power lines.
- DO NOT mount the probe vertically when used for above-ground applications.

LOCATION OF THE CT-6 PROBE

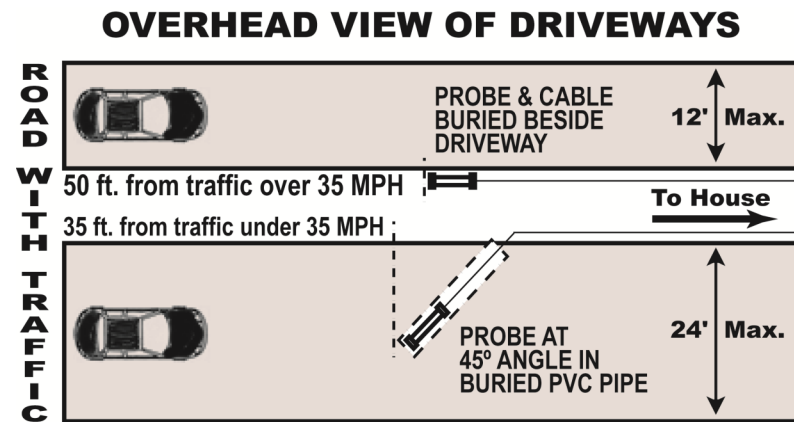

Figure 3

See Figure 3. The sensing range of a probe buried beside the driveway is 5 to 8 feet with a small car going 5 MPH. Taking the width of the car and the sensing range, this system covers a 12 foot wide driveway. Buried in the middle of the driveway, this system can cover up to a 24 foot wide driveway (see "Installing CT-6 Probe and Cable," p. 5).

The probe should be at least 35 feet back from a street on which cross traffic is going under 35 MPH and at least 50 feet back from a street on which cross traffic is going over 35 MPH. If the probe is installed in the center of a 12 foot wide driveway, it can be 20 feet or 35 feet back from traffic

INSTALLING CT-A1 SOUNDER (replacement sounder for FC-9, CT-8 and CT-8A)

See Figure 5.

Connect wires to CT-A1 first, test resistance, then connect to the CF-2C.

♦ At CT-A1, connect a wire to terminal "V." At CF-2C, test resistance and connect this wire to terminal 6.

♦ At CT-A1, connect a wire to terminal "G." At CF-2C, test resistance and connect this wire to terminal 15.

♦ At CT-A1, connect a wire to terminal "S" (for steady tone) or "P1" (for fast pulsating tone) or "P2" (for slow pulsating tone). At CF-2C, test resistance and connect this wire to terminal 14.

♦ At CT-A1, connect a wire to terminal "E." At CF-2C, test resistance and connect to terminal 9.

♦ At CT-A1, connect a wire to terminal "R." At CF-2C, test resistance and connect to terminal 10.

♦ At CT-A1, connect a wire to terminal "M." At CF-2C, test resistance and connect to terminal 8.

INSTALLING CT-11 SOUNDER

See Figure 2 on page 2. Please read the instructions in the introduction. First make the connections at the CT-11 plate and then to the control unit as follows:

Connect one colored wire to the terminal marked "-". At the control unit, test the resistance as noted above. Then proceed to connect this wire to terminal 15.

Connect another colored wire to the terminal marked "+". At the control unit, test the resistance as noted above. Then proceed to connect this wire to terminal 14.

INSTALLING AA-1 & CT-11 SOUNDERS

See Figure 2 on page 2. Connect the RED lead to the terminal marked SON (or +) on the sounder. Connect the BLACK lead to GND (or —) on the sounder. At the control unit, test the resistance RED to BLACK as noted above. If resistance proves correct, at the control unit connect the RED lead to terminal No. 14. Twist the BLACK lead to the SHIELD wire and connect to terminal No. 15.

ADJUSTING CT-A1 EXIT DELAY

See Figure 6. The exit-delay time (potentiometer "C") can be adjusted from 50 seconds to 15 minutes. To determine the exit delay time, first remove the RED probe wire from terminal No. 17. This will put the CF-2C into PROBE FAULT mode (see page 6). When the exit delay timer times out the annunciator relay will constantly cycle on and off.

To activate the exit delay timer on an installed CT-A1 annunciator, press the exit delay button on the annunciator plate. If other devices are being used to activate the exit delay timer (such as an alarm panel, etc.), take a wire and short the terminals between No. 9 and No. 15 at the CF-2C control panel. Doing this for 2 seconds will trigger the timer. When the timer is activated, the annunciator relay will stop cycling.

Measure the time from when the relay stops and when the relay begins cycling again and you will know the exit delay time. For longer exit delay time, adjust the potentiometer marked "C" clockwise and repeat until the desired time is achieved. Re-attach the RED probe wire to terminal No. 17 when finished.

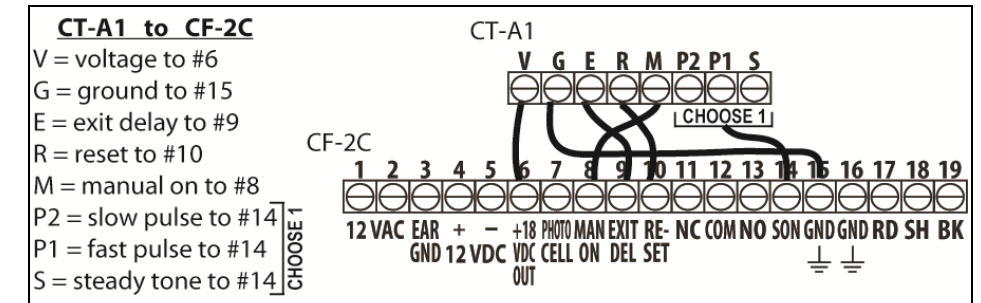

Figure 5

WIRE CHECK-OUT

After connecting wires to the sounder, and before connecting to the control unit, systematically measure the resistance between each wire with every other wire. **Resistance should never be less than 75 ohms.** Resistance less than 75 ohms shows damage to the wire between control unit and sounder (e.g., a staple through the wire) and will damage the power supply if it is connected to the control unit.

CT-A1 SOUNDER FEATURES AND INSTALLATION INSTRUCTIONS

THREE TONES

The CT-A1 allows three tones: steady, slow-pulse, fast-pulse. It is suggested the installer sample the tones for the customer to choose. To hear a sample of the steady tone, push the button marked "PROG." To hear a sample of the slow-pulse tone, push the button marked "DOWN." To hear a sample of the fast-pulse, push the button marked "UP." Note: power must first be applied to the CT-A1 before it will sound.

PROGRAMMING VOLUME

To adjust volume, keep the button marked "PROG" pushed in the entire time you are increasing or decreasing volume (it will continue to sound as long as it is pushed in, demonstrating adjusted volume).

With "PROG" pushed in, push the button marked "UP" to increase volume one increment. Keep "PROG" pushed in, wait one second, and push "UP" again. Repeat until desired volume is reached.

With "PROG" pushed in, push the button marked "DOWN" to decrease volume one increment. Keep "PROG" pushed in, wait one second, and push "DOWN" again. Repeat until desired volume is reached. Note: when highest or lowest volume setting is reached, the LED will blink once.

MUTING SOUNDER

To mute sounder, keep "PROG" button pushed in and push the "DOWN" button two times in quick succession (in less than one second). The LED will begin blinking and continue blinking the duration of the mute cycle. To restore sound, hold "PROG" button down and push the "DOWN" button two times in quick succession as before. The LED will stop blinking when sound is restored to its previous setting.

ADJUST TIMING (OPTIONAL)

The default timing for the CT-A1 is set at the control unit (see "Adjusting Sounder (Annunciator) Time" on page 10). However, if a longer sounding time is desired for individual CT-A1's, it can be lengthened by turning the pot on the sounder's circuit board counter-clockwise (CCW).

"ON", "RESET" and "EXIT" ADDITIONAL FEATURES AND "CHIRP"

The CT-A1 has additional features made available by three function-buttons on the plate:

The "ON" button instantly trips the floodlight timer and the floodlights are switched on for the time period set by the control unit or until the "RESET" button is pushed.

"RESET" instantly cancels the floodlight timer and turns off the lights operated by the CF-2C.

"EXIT" button activates the preset exit delay timer, de-activating the sensor probe. This allows a vehicle to drive by the probe without tripping the system, Normal standby mode occurs after the exit delay timer times out (see "Adjusting CT-A1 Exit Delay," on page 9).

These buttons lack a tactical feel, but when pushed, a small audible "CHIRP" should be heard.

SPECIAL NOTE: Many installers use the CT-A1 as a means of safety for the woman home alone at night. By installing the CT-A1 just outside or inside the master bedroom, one need only push the "On" button from the convenience of the bedroom when suspicions are raised by outside noises. Doing so will turn on all lights operated by the CF-2C and inform outsiders, if they exist, that they have been detected.

respectively. (You must adjust the probe's sensitivity (GAIN). See "Adjusting Probe Sensitivity" on page 11.)

Stationary steel near the probe, but not over the probe, will not affect its operation. The probe can be placed in a PVC pipe under the steel-reinforced grid of a concrete roadway without affecting its operation.

Probes installed above ground should be mounted no higher than 2 feet above the road surface. If the probe is attached to a wall or post, it should be mounted parallel to the ground and parallel with the driveway. Rule of thumb: the vehicle must approach one end of the probe, not both at the same time. If a car approaches both ends of the probe simultaneously (i.e., it is installed across, and not parallel with, approaching traffic) the signal will be cancelled.

In drive-up window applications, install the probe at least 15 to 20 feet before the window.

INSTALLING CT-6 PROBE AND CABLE

See Figure 3 on page 4. Typically, the probe is buried 6-10 inches below ground, beside, and parallel to, the driveway. It is advisable to bury 6-10 feet of extra cable with the probe (coiled up) for future maintenance or relocation.

When installing the probe in existing pavement, bore a 1.5 inch diameter hole vertically, 18 inches deep. Slice the pavement from the bored hole to the driveway edge to accommodate the cable. Install the probe and cable and seal with silicon.

When installing the probe within a dirt or gravel driveway, first bury a 2 inch schedule 80 PVC pipe in the center of the driveway, 6-8 inches deep, and diagonally at a 45 degree angle (see Figure 3 on page 4). Slide the probe and cable to the end of this pipe. This will make it easily retrievable in the future.

When installing in new construction, bury the 2 inch PVC pipe under the driveway as described above. Then pour cement or asphalt the drive. Insert the probe and cable after landscaping is complete to prevent possible damage to the cable.

The probe cable is direct burial and does not require conduit. Depth of burial depends on lawn conditions. In cultured grass, bury the cable 2-3 inches deep. The root system of the grass will capture the cable for life. Use a lawn edger to slice a 1/4 inch wide trench across the lawn to the location of the control unit. Push the cable to the bottom of the slice, fill, and tamp.

In uncultured field grass or in soil without cultured grass, bury the cable at least 6-8 inches deep. When installing the cable through woods or above ground, run it in PVC pipe for mechanical protection, as animals will chew through the cable if it is exposed.

When pulling the cable through conduit or PVC pipe, it is important that every inch of cable be liberally lubricated. Use a wire lubricant, and pull only 100 feet or less at one time. The cable is coated with polyurethane and therefore has extremely high traction. This can cause a tremendous drag when not lubricated; enough to inconspicuously snap wires inside the rubber casing. Therefore, make sure you lubricate it when pulling it through non-magnetic conduit or PVC pipe.

Also, the polyurethane coating on the probe cable demands that extreme care be taken when unrolling it. To unroll, put your arm through the center of the roll, remove the tape, and unravel the roll one wrap at a time. Once you begin unrolling the cable, do not lay it down before you are finished or it could become irreparably tangled.

Note: Because the cable is fully shielded, it can be buried in the same trench (but not the same conduit) in which there are water, power and telephone lines, if codes permit. Check all electrical codes, both locally and nationally.

CONNECTING CT-6 PROBE TO CONTROL UNIT

See Figure 2 on page 2. At the control unit, connect the RED probe wire to terminal No. 17; connect SHIELD (Drain) wire to terminal No. 18; and connect the BLACK wire to terminal No. 19.

MULTI-PROBE ASSEMBLIES

See Figure 4. The CF-2C system can support up to 100 standard CT-6 probes without loss of sensitivity when wired in series. The probes should be hooked up as shown in Figure 4. All interconnections must be soldered and taped. Solder-tin the leads before connecting to terminals Nos. 17, 18, and 19.

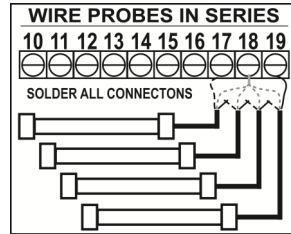

Figure 4

PHASING PROBES

Phasing of multi-probe assemblies is important when a probe is placed on both sides of the same driveway, or several probes are linked together to cover a large area. Phasing is not important in installations where a vehicle does not pass between two probes, such as probes used on separate driveways or when several probes are linked together at greater than 50 foot intervals. The phase output of the probe is controlled at the time of manufacturing. Please contact technical support at 717-532-0033 for more information.

PROBE SYSTEM SUPERVISION

When the probe wire is cut or the probe has been damaged by lightning (and thereby “open-circuited”) or the BLACK wire is shorted to the SHIELD wire, the PROBE FAULT red LED light located on the circuit board will light and the sounder(s) will continuously cycle on and off, indicating the probe system has been violated.

For example, if yard work was being done and the CF-2C went into PROBE FAULT mode, that would indicate when the wire was damaged. In high security areas, this feature is extremely valuable.

If the RED and BLACK probe wires are shorted together, the PROBE FAULT SYSTEM will not go into alarm mode and the CF-2C control will not respond to the probe or the TRIP TEST button.

If the circuit board has stopped working, use the instructions in “USING PROBE FAULT MODE FOR TESTING” (see below) to test the CF-2C circuit board. To test the probe for possible damage, refer to “CT-6 Probe and Wire Check-out” on page 3.

SPECIAL NOTE: *To disarm the sounder cycle and to test the circuit board when in the PROBE FAULT mode, remove the probe wires from terminal Nos. 17, 18, and 19; then short out terminals No. 17 and 19 by connecting a wire between them. The PROBE FAULT light should immediately go out and the cycling should stop in about a minute. If the LED does not go out, there is component failure on the circuit board.*

Another way to stop the cycling is to cut the “stand up” diode lead of D2. D2 is located center right on the board to the right of, and adjacent to, the TRIP TEST button. The board is marked in white letters “D2” under the diode.

USING PROBE FAULT MODE FOR TESTING

With power applied and the probe wires disconnected, if the LED does not light, there may be power supply failure. If the LED does light but does not cycle the annunciator(s), the cause may be related to one of three things:

1. The exit delay timer has not timed out (see “Adjusting CT-A1 Exit Delay” on page 9.)
2. Wiring problems going to terminal No. 9
3. Component failure on the circuit board

Other uses in PROBE FAULT mode:

The cycling of the sounders can be used to set CT-A1 exit delay time (see page 9), annunciator duration (see page 10), and re-trigger hold-off time (see page 10). It may also be used to check all of the sounders without the need for a vehicle tripping the system.

SD-6 SHORT DRIVEWAY PROBE SYSTEM

The SD-6 is a dual-probe set that works with the CF-2C and differs from the CT-6 in that it can be as close as 10 feet to outside cross traffic. Only one SD-6 system can be used with a CF-2C control unit. For installation instructions, please refer to the manual accompanying the SD-6 dual-probe system.

CONNECTING OTHER SENSING DEVICES TO CONTROL UNIT

See Figure 2 on page 2. The CF-2C is engineered to accept other sensing devices in conjunction with or exclusive of the CT-6 probe. You may use as many and as varied sensing devices as you like. To do so, you will need the following:

1. A sensing device with a normally open, floating, dry relay contact
2. A 500 - 1000 ohm resistor

To connect your sensing device to the CF-2C, attach one side of the device to terminal 17, the other side to terminal 19 and place a 500 - 1000 ohm resistor across those two terminals.

INSTALLING PHOTOCELL BLOCK

See Figure 2 on page 2. The FC-6 photocell is designed to be mounted on a window pane with its “eye” looking outside. Its distance from the control unit is not important.

To insure good adhesion, clean the window area with alcohol. Peel off the double-sided tape cover paper and mount the photocell on the window. The hole on the sticky side of the photocell should be at the top, and the screw terminals situated so that the wires will be connected from the top.

Using a 2-wire, shielded cable, connect the two primary wires to the screw terminal on the photocell. The shield drain wire does not connect to anything on the photocell. Cut it off there.

At the CF-2C control unit, connect the SHIELD drain wire to terminal No. 16, and the two primary wires to terminals No. 7 and 15 (see Figure 2 on page 2).

Note: Static discharge from lightning can damage the photocell. It is therefore important to use shielded cable for photocell hook up.

SPECIAL NOTE *The FC-6 and FC-12 photocells are manufactured by Cartell and function as a light sensitive resistor. Measuring with an ohm meter, the resistance generally will be in the 2000 to 5000 ohm range in full sunlight. As the light diminishes, the resistance instantly goes up. The CF-2C floodlight timer circuit is locked out when the resistance is below 1 mg-ohm. When measuring the resistance between the two leads going to the photocell, if the resistance does not vary with a change in light level, the photocell may have been damaged by lightning; if it is shorted or open, there may be wire damage. A lightning damaged photocell or a shorted wire will keep the CF-2C lights from coming on at night. An open wire to the photocell will allow the lights to come on day and night.*

INSTALLING SOUNDERS (ANNUNCIATORS)

MOUNTING

Install sounders in a single-gang electric box for flush mounting.

WIRE

Use CAT-5 wire. To avoid corrosion, solder-tin the ends of the wires before connecting to the sounder and control unit. Always connect the wire to the sounder first and then to the control unit.