

CW-SYS to All-O-Matic SW-300DC, SW-325DC, & SW-350DC

Note If powering operator via solar panels, be sure to compensate for the 25mA standby current draw of the CW-INT

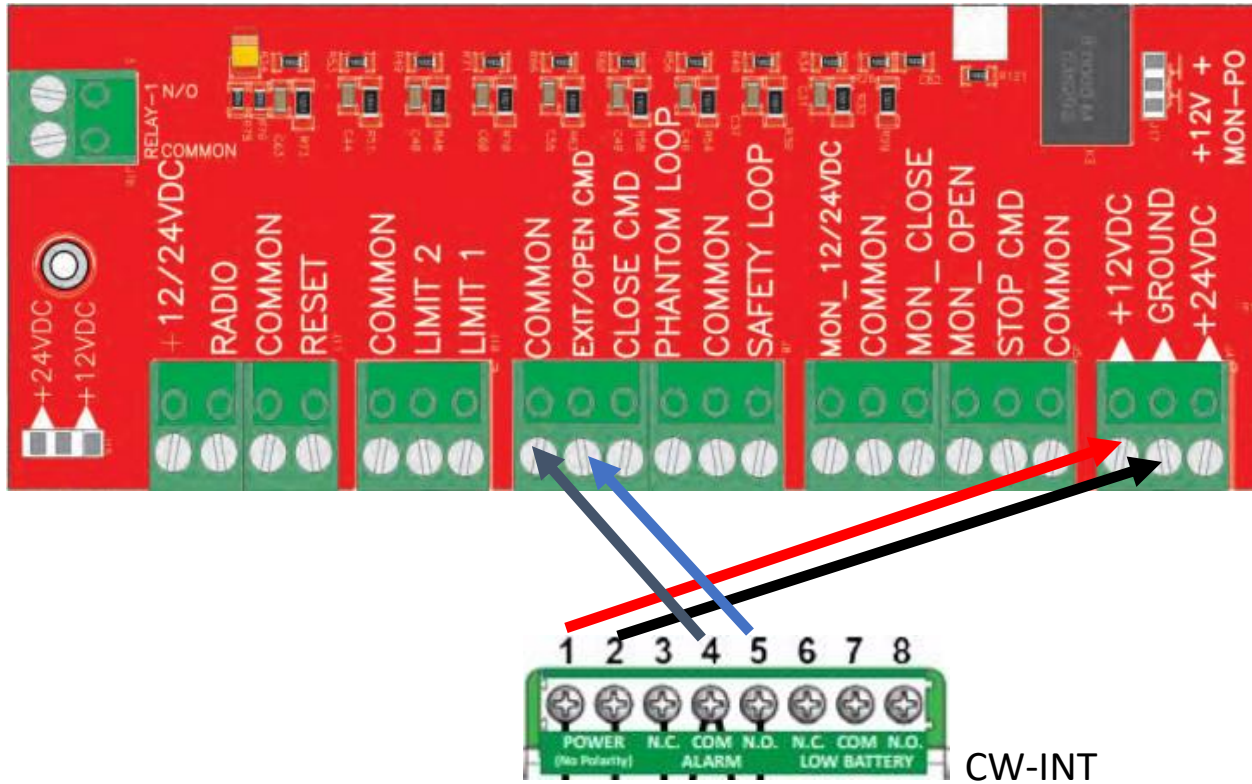

CW-INT

Terminals 1 & 2 are power 8-24 VAC or 8-28 VDC.

Terminal 4 is relay common.

Terminal 5 is normally open.