

CF-2C and CW-SYS Wiring Diagram

The CW-SYS unit can be used to replace the CT-6 probe on a CF-2C system. Follow the instructions below to complete the installation.

Connect the wires to the following terminals:

CF Board

Terminal 6 (VDC OUT) to
 Terminal 15 or 16 (GRD) to
 Terminal 17 to
 Terminal 19 to

Integrator

Terminal 1 (Power Input)
 Terminal 2 (Power Input)
 Terminal 4 (COM)
 Terminal 5 (NO)

You may also choose to power the Integrator with a separate power supply.

CW-SYS = Dual Purpose Wireless System

CW-REP = Wireless Repeater

CW-PSU = Power Supply

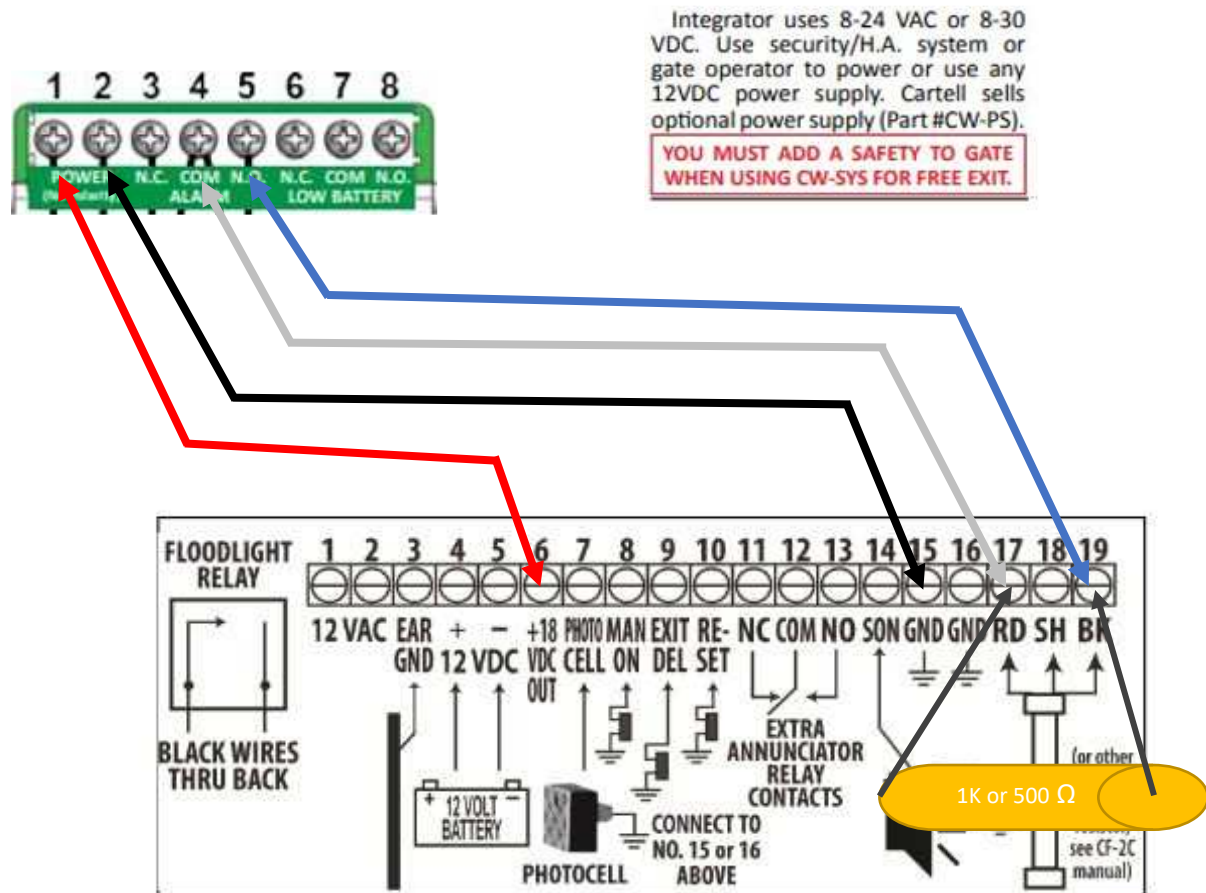

Figure 2

Connect a resistor between terminals 17 and 19. 500 or 1K ohms would be fine. That will assist in eliminating a probe fault alarm.