

Important Receiver Installation Notes:

- 1) Be sure the unit is sealed from moisture, and if possible keep it away from direct moisture.
- 2) In those installations where vibration may be a factor, be sure to use a fastening compound, such as LOCTITE™ on the mounting screws.
- 3) If this, or any other equipment is being used in a safety-related device, be sure to test the entire system at the time of installation, and at frequent intervals, to determine that it is working properly.

SECTION #4

OPERATIONAL CHECK

To check operation, move back about 50 feet and press the transmitter button. Operation should be reliable at this distance but environment and location of both the transmitter and receiver will effect the range. Try different mounting locations and positions, for the transmitter, in the vehicle. If operation is still undesirable, check the following:

- 1) The antenna must be connected to the receiver for normal use.
- 2) If the operator fails to operate, check to see that 110V power is present. Check circuit breakers or for a system power failure.
 - 1) Checking the operator. If the operator will not function when the push button is pressed, the problem is likely to be the operator. If the operator will open by pressing the push button, but not when the radio control button is pressed, the problem is probably in the radios. **Check that both the transmitter and receiver code switches are set to the exact same code.**
- 2) Try mounting the antenna at a more favorable remote location by using the coax antenna kit (part #DC5166).

If, after performing the above operational checks, the controls still do not function, they should be returned to your dealer for repair or replacement.

WARRANTY

All Digi-Code door related products carry an eighteen (18) month warranty against defects in workmanship or material. This warranty begins at the date of manufacture, for eighteen months. Digi-Code warrantees our product only to our authorized dealers and distributors, and not to the end customer. If you have any questions about our warranty, please ask your dealer to determine the nature and scope of their warranty. Digi-Code does not assume, and is not responsible for, any real or consequential damages from claims against the performance of our product, nor is it liable for any costs related to the loss of life, property, or revenue. Further, Digi-Code is in no way responsible for installation of our product, and will assume no cost related to reinstallation or removal. Digi-Code's warranty is in lieu of all other warrantees, expressed, or implied.

CAUTION: Any changes or modifications in intentional or unintentional radiators which are not expressly approved by Digi-Code Inc. could void the users authority to operate this equipment. This applies to intentional and unintentional radiators certified per part 15 of the FCC rules and regulations.

Installation Instructions

Garage Door Opener \ Gate Operator Radio Controls

Model 5150 Dual Frequency(300MHz/ 310 MHz) Light Commercial Receiver 12V \ 24V

WARNING:

- Disconnect operator power before any installation or repair
- Always wear safety glasses

Your Digi-Code radio controls are designed specifically to remotely control a garage door opener \ gate operator and to give years of trouble free service without adjustment. **Because all radio controls are set with the even numbered switches in the "ON" position when they leave the factory, it is recommended that a different code be selected and set at the time of installation.** Please refer to the "Setting the Code Switch" section for instructions. The radio frequency (RF) portion of the controls, however, are tuned to standard frequencies and are thoroughly tested at the factory. This permits the addition or replacement of either the transmitter or the receiver by specifying the Model number and the RF frequency designated on the identification label. RF adjustments are not needed nor should any be attempted.

SECTION #1

SETTING THE CODE SWITCH

Remove the top section of the case to access the code switches. The digital code is determined by the position of the 10 small switches numbered 1 through 10 located in the receiver and the transmitter. Any combination of "on" or "off" positions can be selected by using a pencil or a pen. (Note: The switches are in the "on" position when the switch is depressed toward the number.) - **See Figure #1.** Set code switch positions 1 through 10 to your personal code scheme, (**Note: This setting must match the setting in the transmitter you are going to use to operate this device.**). We strongly urge that several coding schemes be avoided: ALL ON or; 2,4,6,8,10, ON. These positions are similar to our or other manufacturers test positions or are frequently used.

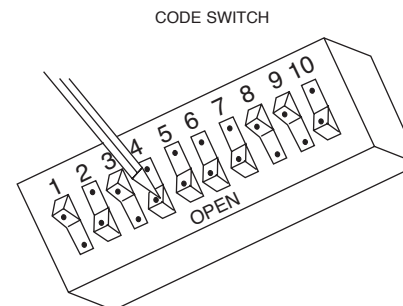

FIGURE #1

SECTION #2

RECEIVER INSTALLATION

Begin your installation by correctly wiring the receiver to the devices you will be using. **WE STRONGLY ADVISE THAT YOU BECOME FAMILIAR WITH THE INSTRUCTIONS THAT THE MANUFACTURER OF YOUR EQUIPMENT HAS PROVIDED, SINCE, IN MANY CASES, THESE INSTRUCTIONS WILL DETERMINE THE WAY IN WHICH THE RECEIVER WILL BE INSTALLED.**

The receiver should be mounted near the operator powerhead and can be installed in any position by using screws and the two slots in the cover flanges. Select a location and position that permits access to the terminals and spade for the antenna as clear of metal structures as possible and preferably in a vertical position.

The receiver comes equipped with a coax antenna receptacle and an antenna with a coax connector. The antenna can be screwed directly into the receptacle, or to an outside location (away from a metal structure) for better receiver performance by using a coaxial kit (Part #DC-5166) available from your dealer.

YOU HAVE PURCHASED THE MODEL 5150 - 12V / 24V RECEIVER

FOR 24VAC OR DC -Wire the red and black wires to a 24V - power supply. If applicable, attach the red wire to the positive terminal (+) and the black wire to the negative terminal (-). Connect the remaining gray wires as specified by the manufacturer of your operator. If not specified, wire the two gray wires in parallel with the push button terminals. If the operator has a three wire terminal, the proper terminals will usually be marked "1" and "2" or "24V" and "RELAY" (see figure #2)

FIGURE #2

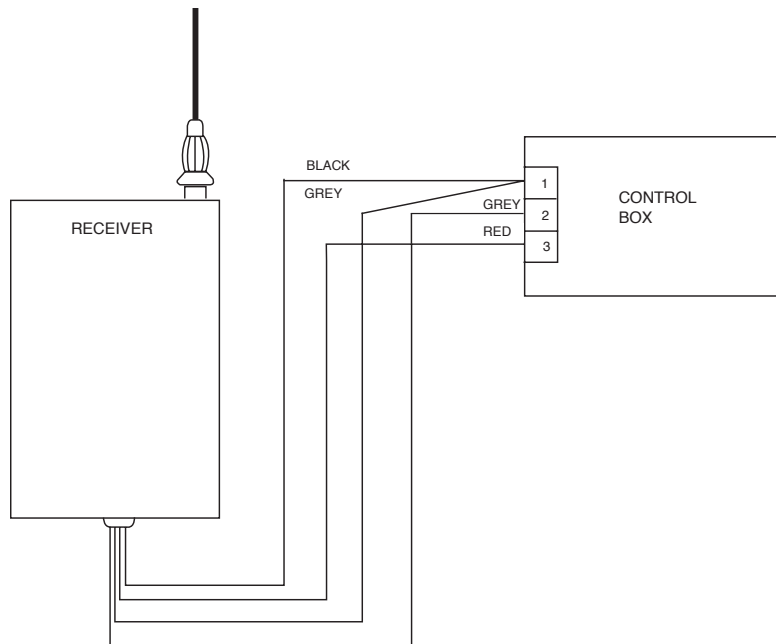

FOR 12VAC OR DC - Wire the red and black wires to a 12V-power supply. If applicable, wire the red wire to the positive (+) 12 volt terminal in the operator and wire the black wire to the negative (-) or ground terminal of the operator. Connect the remaining gray wires as specified by the manufacturer of your operator. If not specified, wire the two gray wires in parallel with the push button terminals (see figure #3)

FIGURE #3

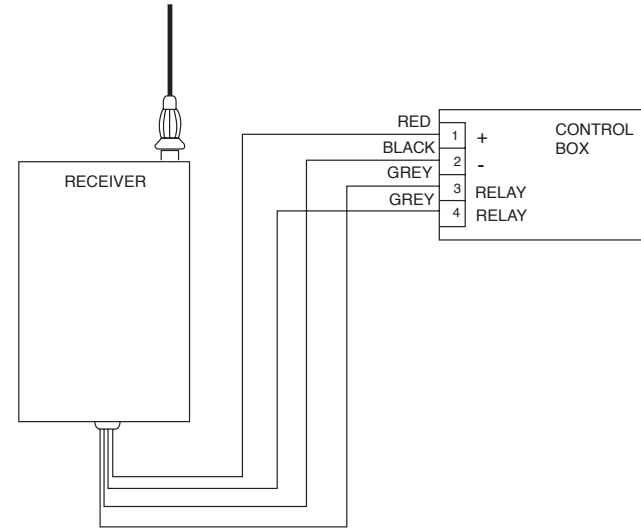

CHANGING THE OPERATION FREQUENCY (Units come set at 300MHz from the factory)

Plug the transformer into a convenient 110 volt outlet. Connect the remaining gray wires as specified by the manufacturer of your operator. If not specified, wire the two gray wires in parallel with the push button terminals. If the operator has a three wire terminal, the proper terminals will usually be marked "1" and "2" or "24V" and "RELAY" (see figure #4)

FIGURE #4

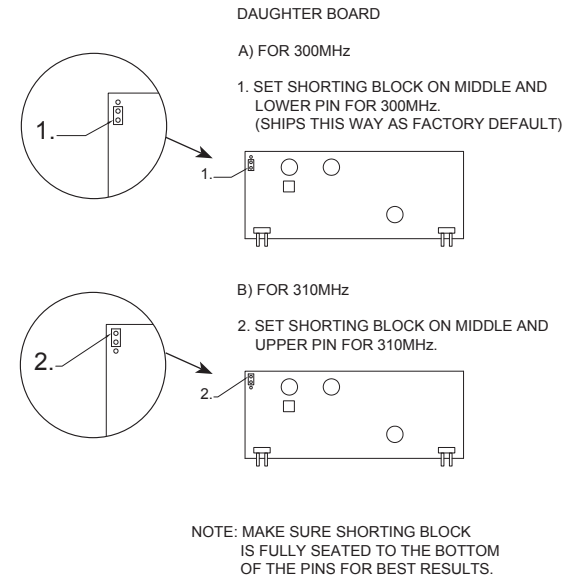

SECTION #3

ANTENNA INSTALLATION

After you have mounted your receiver, test it with the enclosed antenna for range and coverage pattern. If greater range or coverage pattern is necessary, you may need to purchase the coax antenna kit (part DC-5166) from your dealer.