

OVS-6000



ENGLISH

5924371 FEB 2016

MANUFACTURER'S STATEMENT

Read this installation instructions carefully before use to ensure proper operation of this product. Failure to read this operation manual may cause improper operation and may result in serious injury or death of a person. The meanings of the symbols are as follows.

	WARNING	Disregard of the warning symbol can cause improper operation which may cause death or serious injury.
	CAUTION	Disregard of the caution symbol can cause improper operation which may cause injury of a person or damage the object.
	NOTE	Special attention is required to the section of this symbol.
		It is required to check the operation manual if this symbol is shown on the product.

NOTE

- This product is a non-contact switch intended for header mount or wall mount for vehicle detection. Do not use for any other applications.
- When setting the sensor's detection area, make sure that there is no traffic around the installation site.
- Before turning the power ON, check the wiring to prevent damage or malfunction of equipment connected to the product.
- Only use the product as specified in the operation manual provided.
- Be sure to install and adjust the sensor in accordance with the local laws and standards of the country in which the product is installed.
- Before leaving the installation site make sure that the product is operating properly and instruct the building owner/operator on proper operation of the product.
- The product settings can only be changed by an installer or service engineer. When changed, the changed settings and the date shall be registered in the maintenance logbook.

	WARNING	Do not wash, disassemble, rebuild or repair the sensor, otherwise it may cause electric shock or breakdown of the equipment.
Danger of electric shock		

NOTE

- The following conditions are not suitable for sensor installation.
- Fog or exhaust emission around the detection area
 - Wet floor
 - Vibrating header or mounting surface
 - Moving objects, steel plate, emergency lights or illumination in the detection area or in vicinity
 - Highly reflecting floor or highly reflecting objects around the detection area

SPECIFICATIONS

Model	OVS-6000
Detection range	6' 6 3/4" to 19' 8 1/2" (2.0 to 6.0m)
Detection method	Active infrared reflection method
Detection range (Vertical)	-80° to +80° (Deep/Shallow)
Detection range (Right & Left)	360°
Power supply	24VDC
Power consumption	< 2.5W (24VDC)
Current consumption	< 105mA (24VDC)
Operation indicator	Stand-by : LED ON Detection(Only one area) : LED OFF Detection(Any areas) : LED Slow Blinking Infinite detection : LED Fast Blinking
Output	"Form A" relay 100VAC 1A 30VDC 0.1A Max.
Relay hold time	Approx. 1.0sec.
Operating temperature	-4 to 131°F (-20 to +55°C)
Weight	290g (10.2oz)
Accessories	1 Operation manual 2 Mounting screws 1 Mounting template 1 Cable 9'10"(3m)

NOTE The specifications herein are subject to change without prior notice due to improvements.

OUTER DIMENSIONS AND PART NAMES

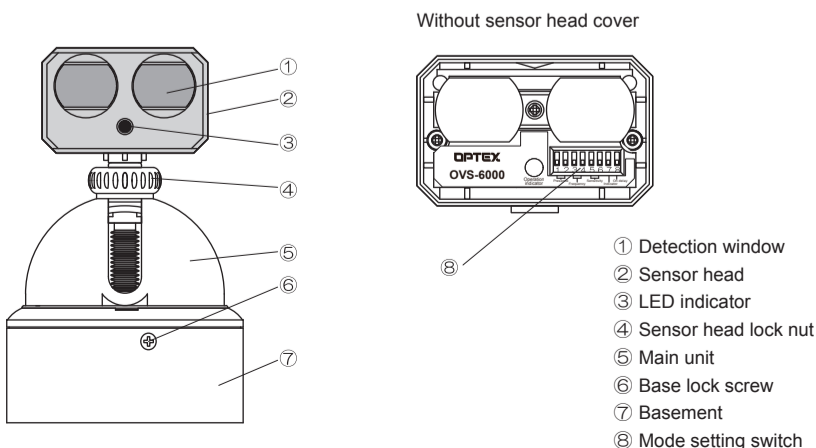
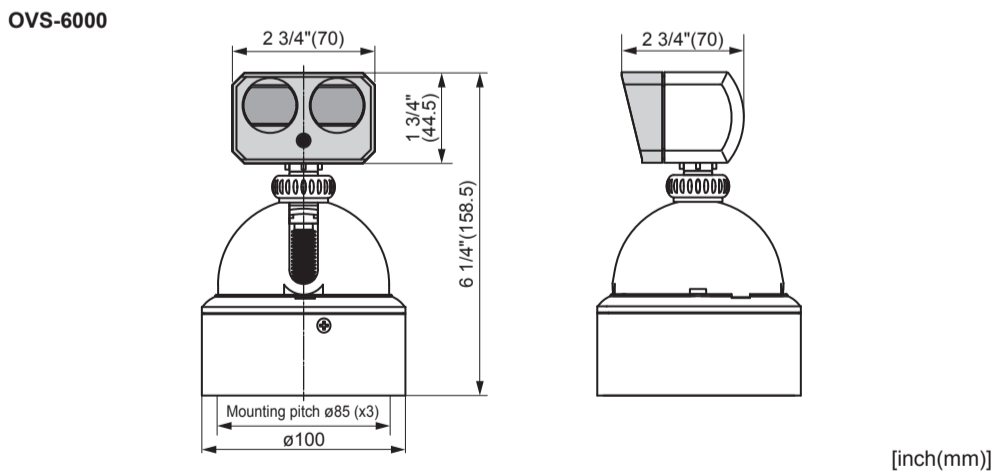

DETECTION AREA

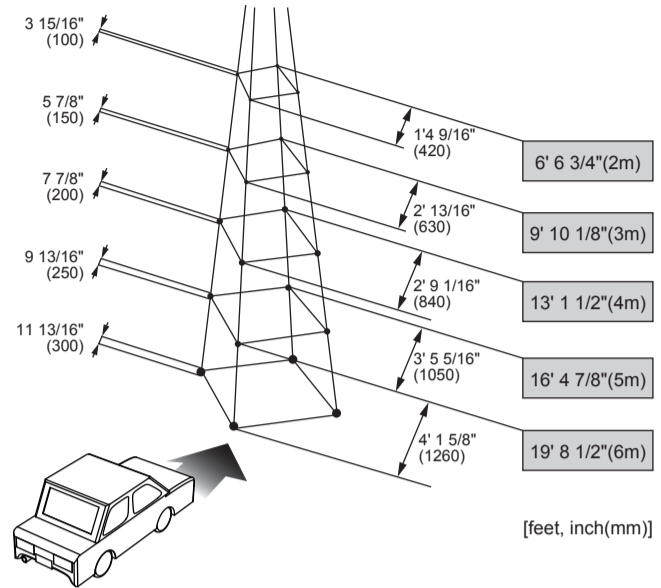

FRONT VIEW

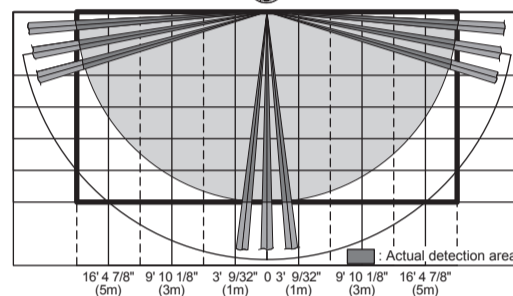

SIDE VIEW

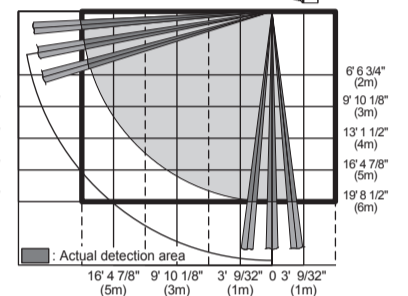

NOTE The actual detection area may become smaller depending on the ambient light, the color / material of the object or the floor as well as the entry speed of the object.

INSTALLATION

1 Install Sensor

(1-1) Drill three mounting holes.

Affix the mounting template put "up side" sign up and make holes. Drill a wiring hole when you pass the cable into the wall.

- Mounting screw holes : $\phi 1/8"$ (3.3mm) (Three positions)
- Wiring hole : $\phi 19/32"$ (15mm) (One in center)

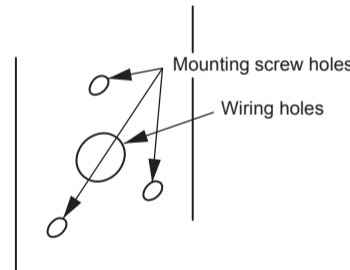

CAUTION : Risk of product failure. Do not install sensors upside down. Otherwise rain water make troubles.	
Right position of the mounting screw holes when install on the side pole.	
Right sensor position when use a angle.	

WARNING : Danger of electric shock.
Make sure to remove burr in mounting holes otherwise damaged cable may cause electric shock.

(1-2) Put attached screws into mounting holes temporary.

(1-3) Break off basement from sensor unit.

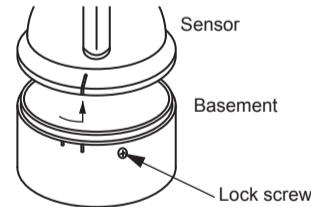

- Loose the lock screw of basement full well.
- Basement can break off when rotate anticlockwise.

(1-4) Set basement onto temporary screws of (1-2)

(1-5) Wiring onto basement (refer to 3-1)

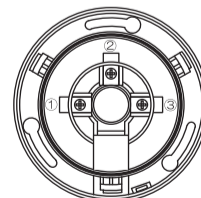

Wiring should be allowed sign of basement.

- ① Power supply ... Red
- ② GND ... Black
- ③ Signal ... White

(1-6) Set sensor unit on basement.

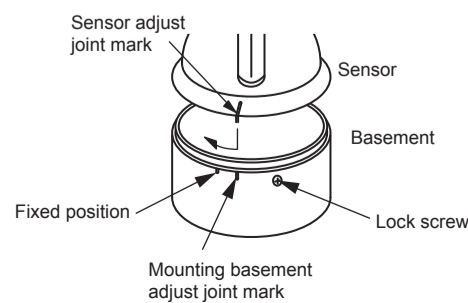

- Push sensor unit onto basement adjust joint mark.
- Rotate sensor clockwise to prescribed position.
- Tight up the lock screw.

INSTALLATION

2 HOW TO WIRING

< Wiring to the controller >

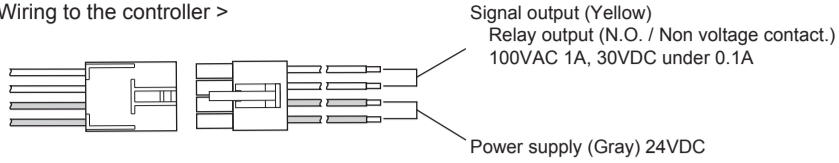

Penetrate connector to the end.
If connector plugged not enough, signal will not stable.

< Sensor connecting cable setting >

Take care following matter when connect sensor cable.

NOTE Sensor cable sensor to sensor : Please use VCTF cable 0.75mm².
Cable length : Please use cable within 32' 9 11/16"(10m) long between sensor to sensor.

ADJUSTMENTS

1 Adjust detection area of right & left direction.

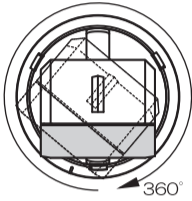

Rotate sensor head angle which position you want.
It can be revolved 360°.
Horizontal angle of detection area adjustment is as left picture.

CAUTION : Risk of product failure.
Never rotate sensor head over three rounds otherwise cable will be broken.

2 Adjust detection area of vertical direction.

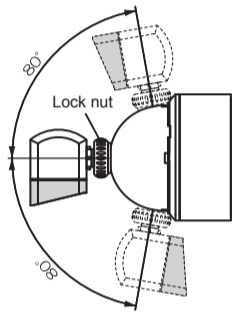

1. Loose sensor head lock nut to anticlockwise direction.
2. Move sensor head angle which you want. And tighten lock nut.
It can be moved up to 80 degrees and down to 80 degrees.

3 Adjust mode switches.

Adjust mode switch is found pull out sensor head cover. Please set dip switches.

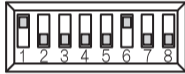

[1] & [2], Presence detection timer. (Sec.)
[3] & [4], Frequency switch setting.
[5] & [6], Adjust detection area length. (Sensitivity)
[7], Adjust LED indicator setting.
[8], Adjust On delay.

(3-1) Adjust presence detection time setting
Adjust presence time by mode switch [1] & [2]
Attention : All detection area are adjusted.

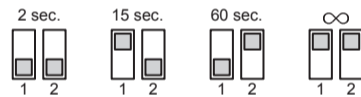

Other than Infinity, will be changed to the presence time is 10 minutes when the area has multiple detection.

< Presence detection >

After power ON, please wait 10 sec without moving object in the detection area.
Presence detect function will be done by this.

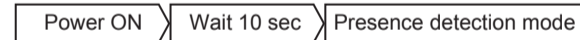

< Infinity mode switch setting >

When Infinity presence detection mode is on, LED indicator is [Fast Blinking], and keep detection during the object is in the detection area.

< CAUTION : When you use infinity mode on >

If the reflection ratio of floor condition will be changed by sudden rain or heavy snow, sensor will be failure and keep detection.
If happen above situation, please cut power OFF and ON again. (Reset sensor)

(3-2) Adjust frequency switch setting

Mode switch [3] & [4] could adjust four kinds of frequency position.

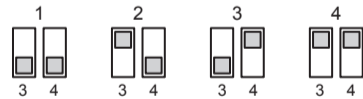

< Frequency switch setting >

When using more than one sensor close to each other, set the frequency different for each sensor.

(3-3) Adjust sensor detection area length (Sensitivity)

Mode switch [5] & [6] could adjust detection area length (Sensitivity).

Set the sensitivity according to the mounting height.
Values below dipswitch are reference only.

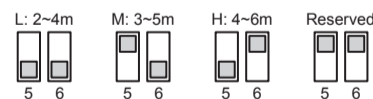

< Detection area length switch setting >

[Detection area length] is rough indication. Depend on object or environment the effectual sensitivity will be changed. Please re-adjust the switch position.

(3-4) Adjust LED indicator setting

Mode switch [7] turn on the LED indicator in usual.

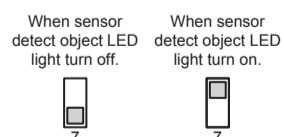

< Adjust indicator switch setting >

- Turn on when detect : When sensor detect object LED light turn off. LED light indicator is on when waiting.
- Always turn on: LED light indicator is always turn on whenever sensor detect object or not.

When you getting close to the detection point center on the floor, you can find the LED indicator light is more bright. To use this function, [Always turn on] mode can help to check the detection area on the floor. After check and adjust the detection area, please set the switch to [Turn on when detect] mode.

(3-5) On delay setting

Mode switch [8] could On delay setting.



< On delay setting >

- Normal detection mode: When sensor detect object relay will be on.
- On delay mode: When detect object the sensor relay will be turned on, after keep stay in the area 3 sec.

CHECKING

Check the operation in the operation mode according to the chart below.

Entrance (Image)		Outside of the area	Entry into the area	Stopped in the area	Passed the area	
Indicator	OFF at detection setting	ON	OFF or Blinking	OFF or Blinking	ON	
	Always turn ON setting	ON				
Output	OVS-6000	OFF	On delay detection: Normal setting	On delay detection: 3sec. setting	Within presence time	1.0sec. after passing
		ON	Entry into the area	Stopped 3 sec. or more in the area	ON	OFF

TROUBLESHOOTING

Problem	Possible cause	Possible countermeasures	Title	
			No.	
Does not work	Power voltage	Set to the stated voltage.	SPECIFICATIONS	
	Wire disconnection, connect trouble.	Check the wiring and connector.	INSTALLATION	(1-5) Wiring onto basement
Does not work sometime.	Dirty on the window.	Clean up the dirty on the window.		
It works on normal operation.	Moving object or light source in the detection area.	Adjust detection area or put out the moving object.		
	Detective area of other sensor is lapped over.	Change frequency switch by each sensors.	ADJUSTMENTS	(3-2) Adjust frequency switch setting
	There is some noisy machine near sensor.	Please take the noisy machine away from sensor.		
	Water droppes on the window.	Please re-install in order to avoid the rain water.		
Sensor signal keep on.	Change the floor condition during presence mode.	Please turn OFF the power and ON again.	ADJUSTMENTS	(3-1) Adjust presence detection time setting

If the trouble could not solve, please call installer or service staff.

INFORM BUILDING OWNER / OPERATOR OF THE FOLLOWING ITEMS

WARNING

1. Always keep the detection window clean. If dirty, wipe the window with a damp cloth. Do not use any cleaner / solvent.
2. Do not wash the sensor with water.
3. Do not disassemble, rebuild or repair the sensor yourself, otherwise an electric shock may occur.
4. Always contact your installer or service engineer when changing the settings.
5. Do not paint the detection window.

NOTE

1. When turning the power ON, always walk-test the detection area to ensure the proper operation.
2. Do not place any objects that move or emit light in the detection area. (e.g. plant, illumination, etc.)