



RBAND

MONITORED EDGE TRANSMITTER

INSTALLATION INSTRUCTIONS

In partnership with
jcm tech

Model: RB-TX10



MillerEdge®

IMPORTANT: READ AND UNDERSTAND ALL INSTRUCTIONS BEFORE BEGINNING INSTALLATION

The Miller Edge RBand Monitored Transmitter is intended to provide a wireless connection between a monitored sensing edge and a motorized operator. RBand Transmitters and Receivers meets the 2016 UL 325 requirements for monitored devices and have been certified as UL 325 Recognized Components. RBand is designed for use with operators that comply with 2016 UL 325 using a Miller Edge 10K Sensing Edge.

1. PARTS LIST

Kit Contents:

1. RBand Edge Transmitter (RB-TX10)
2. (2) 3.6V AA lithium batteries*
3. (4) #6 pan head transmitter mounting screws

*Replacement **3.6V AA lithium batteries** can be purchased at your local electronics store or via Miller Edge.

Required:

- Miller Edge RBand 10K Edge Receiver (Door: RB-D-RX10 or Gate: RB-G-RX10)
- 1/8" flat blade screwdriver
- 1/4" flat blade screwdriver
- Miller Edge 10K (T2/blue band) Sensing Edge

Recommended:

- Multi-meter capable of reading 10KΩ

2. TRANSMITTER: PROGRAM MODE

- 2-1. Confirm the Receiver is powered up. Prior to mounting the Transmitter, remove the cover and insert the batteries, noting their polarity. The **green LED** should blink to indicate that the Transmitter has not been associated with the Receiver yet [IMAGE 1].
- 2-2. To enter **learn** mode, press and hold the Receiver **program button** for ~2 seconds until the **R1 LED** turn on, then release the button.
- 2-3. Press the Transmitter **program button** for ~2 seconds. The Receiver should **beep**. Wait 10 seconds for an additional **beep** to indicate that programming is complete.

Note: Refer to Miller Edge RBand Receiver installation instructions for options for additional Transmitters.

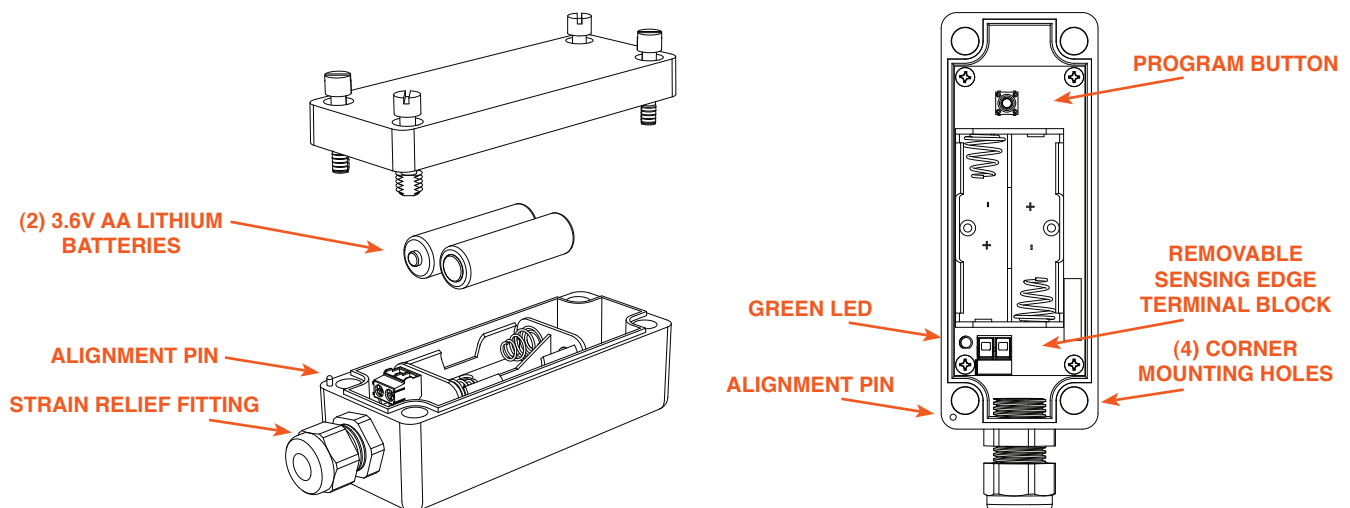

IMAGE 1. RBAND Transmitter

RB-TX10_Install_20170531

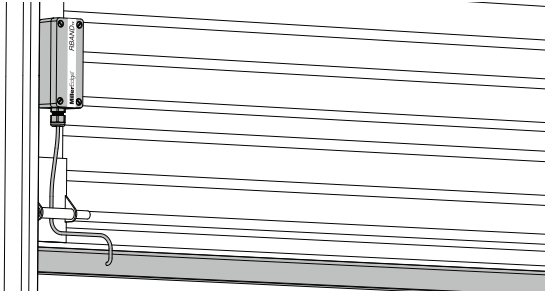

IMAGE 2. RBand Transmitter with Door Edge

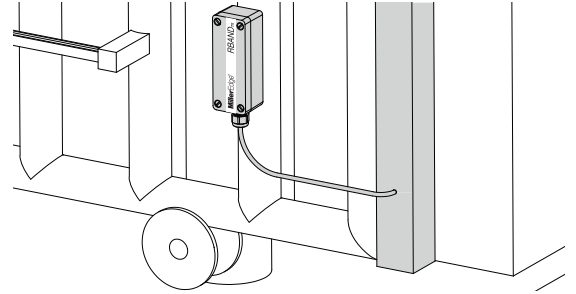

IMAGE 3. RBand Transmitter with Gate Edge

3. TRANSMITTER: INSTALL & TEST

- 3-1. Strip back approximately 2 inches of outer covering of sensing edge cable, then feed through Transmitter **strain relief fitting** [IMAGE 1]. Connect the two sensing edge wires to the removable terminal. Dress the wires with a small service loop and tighten the strain relief. Mount unit utilizing the mounting holes at the 4 corners of the Transmitter box. Affix lid to Transmitter, noting **alignment pin** [IMAGE 1].
- 3-2. Test the sensing edge for functionality.

4. TRANSMITTER: SPECIFICATIONS & CONTROLS

Transmitter Frequency: 916 MHz, FSK modulation

TX Indicator Lights:

- Green LED: Normally off
- Press PROG button for status

Mounting: 4 corner screws (provided)

Power Source: Batteries: 2 AA, 3.6V lithium, 2 year life expectancy

Dimensions: 1.80”L x 4.78”W x 1.75”H

Program Button: Momentary push button is used to associate the Transmitter to the Receiver.

5. FCC COMPLIANCE

Model: RB-TX10

FCC ID: U5Z-RB-TX10

This device complies with Part 15 of the FCC rules. Operation is subject to the following two conditions:

1. This device may not cause harmful interference and
2. This device must accept any interference received, including interference that may cause undesired operation.

This device complies with FCC radiation exposure limits for an uncontrolled environment. This device shall be installed and operated with a minimum distance of 0.4” between users or bystanders and the device. This equipment has been tested and found to comply with the limits for a Class B digital device, pursuant to Part 15 of the FCC Rules:

These limits are designed to provide reasonable protection against harmful interference in a residential installation. This equipment generates, uses and can radiate radio frequency energy and, if not installed and used in accordance with the instructions, may cause harmful interference to radio communications. However, there is no guarantee that interference will not occur in a particular installation. If this equipment does cause harmful interference to radio or television reception, which may be determined by turning the equipment off and on, the user is encouraged to try to correct the interference by one or more of the following measures:

1. Re-orient or relocate the receiver antenna
2. Increase the separation between the equipment and the receiver
3. Connect the equipment into an outlet on a circuit different from that to which the receiver is connected
4. Consult the dealer or an experienced radio/TV technician for help

Changes or modifications not expressly approved by the party responsible for compliance could void the user’s authority to operate the equipment.